

# PRODUCT SUBMITTAL

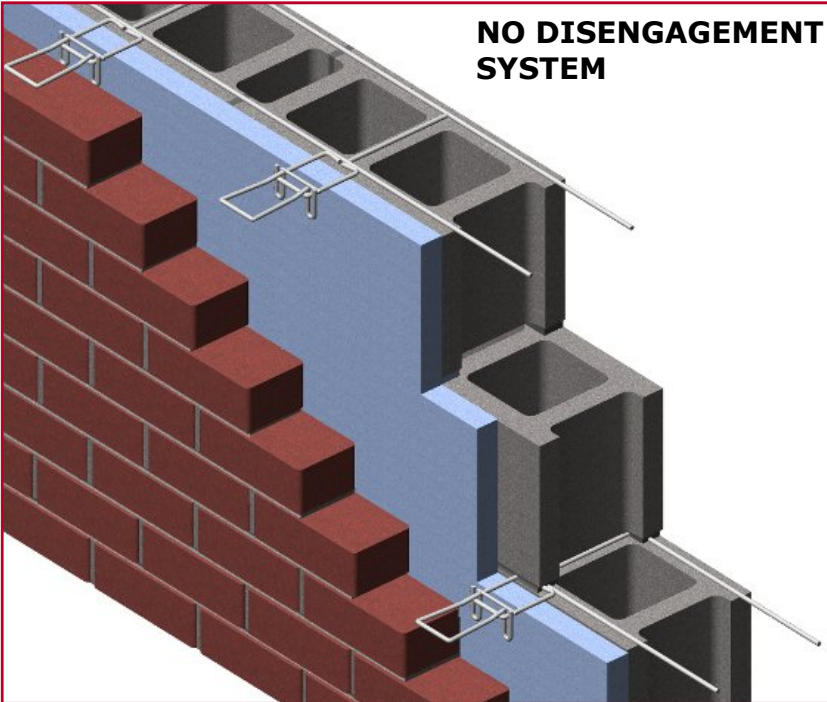

## Ladder Adjustable Tab Lock



Cross rods welded 16" O.C.

- Tab is butt welded to side rod 16" O.C.
- Height of tab will not exceed 3/16" in bed joint.
- Easier to maintain 3/8" mortar joint.

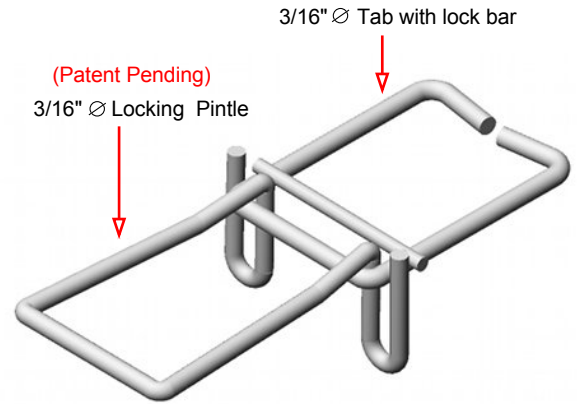

**MEETS 150 MPH WINDLOAD AT FULL ENGAGEMENT AND FULL DISENGAGEMENT**

- looped hooks meet tolerance of 1/16" between adjustable parts.
- Tab Lock design will not disengage meeting **ACI 530 Code Requirements**.
- Adjustable ties have higher ultimate load values at maximum misalignment of 1-1/4".
- Tab Lock system allows loads to be directly transferred from veneer to stronger back-up wall.
- Locking ties wedge insulation against block back-up.

MATERIAL CONFORMANCE	SIZES / FINISHES												
<p><b>ASTM A82 / A82M</b> - (Cold drawn steel wire) Tensile Strength - 80,000 psi Yield Point - 70,000 psi</p> <p><b>ASTM A951 / A951M-06</b> - (Standard Specification for Steel Wire for Masonry Joint Reinforcement)</p> <p><b>ACI / ASCE 530</b> - (Building code requirements for masonry structures)</p> <p>Mill Galvanized / Zinc Coating: <b>ASTM A641 / A641M (0.10 Oz per sq ft)</b></p> <p>Hot Dip Galvanized after fabrication / Zinc Coating</p> <p><b>ASTM A153 / A153M-B2 (1.50 oz per sq ft)</b></p> <p>Stainless Steel <b>ASTM 580 / ASTM 580M Type 304</b> (Type 316 available on special order)</p> <p style="text-align: center;"><b>Recycled Content:</b> Mill Galvanized &amp; Hot Dipped, 82.8% Post-Consumer 17% Post Industrial / Pre-Consumer,</p> <p style="text-align: center;">Stainless Steel, Jl % P: ^E[ ] * * { ^! V O C Content - 0%</p>	<p><input type="checkbox"/> Hot Dip Galvanized after fabrication / Zinc Coating <b>ASTM A153 / A 153 - B2 (1.50 oz per sq ft)</b></p> <p><input type="checkbox"/> Stainless Steel <b>ASTM 580 / ASTM 580M Type 304</b> (Type 316 available on special order)</p> <table style="width: 100%; border-collapse: collapse; margin-top: 10px;"> <thead> <tr> <th style="text-align: left; border-bottom: 1px solid black;">WIRE SIZE:</th> <th style="text-align: center; border-bottom: 1px solid black;">Side Rods</th> <th style="text-align: center; border-bottom: 1px solid black;">Cross Rods</th> </tr> </thead> <tbody> <tr> <td><input type="checkbox"/> Standard</td> <td style="text-align: center;">9 Gauge (.148 in)</td> <td style="text-align: center;">9 Gauge</td> </tr> <tr> <td><input type="checkbox"/> Heavy Duty</td> <td style="text-align: center;">3/16" (.187 in)</td> <td style="text-align: center;">9 Gauge</td> </tr> <tr> <td><input type="checkbox"/> Extra Heavy Duty</td> <td style="text-align: center;">3/16" (.187 in)</td> <td style="text-align: center;">3/16"</td> </tr> </tbody> </table>	WIRE SIZE:	Side Rods	Cross Rods	<input type="checkbox"/> Standard	9 Gauge (.148 in)	9 Gauge	<input type="checkbox"/> Heavy Duty	3/16" (.187 in)	9 Gauge	<input type="checkbox"/> Extra Heavy Duty	3/16" (.187 in)	3/16"
WIRE SIZE:	Side Rods	Cross Rods											
<input type="checkbox"/> Standard	9 Gauge (.148 in)	9 Gauge											
<input type="checkbox"/> Heavy Duty	3/16" (.187 in)	9 Gauge											
<input type="checkbox"/> Extra Heavy Duty	3/16" (.187 in)	3/16"											



**Corporate Office:** 400 Rountree Rd Charlotte, NC 28217  
TEL: (800) 849-6722 FAX: (704) 525-3761

**Mailing Address:** P.O. Box 240988 Charlotte, NC 28224



[www.wirebond.com](http://www.wirebond.com)

**Memphis Plant:** 2365 Harbor Ave. Memphis, TN 38113  
TEL: (800) 441-8359 FAX: (901) 775-9449

**Mailing Address:** P.O. Box 13124 Memphis, TN 38113