

PRODUCT SUBMITTAL

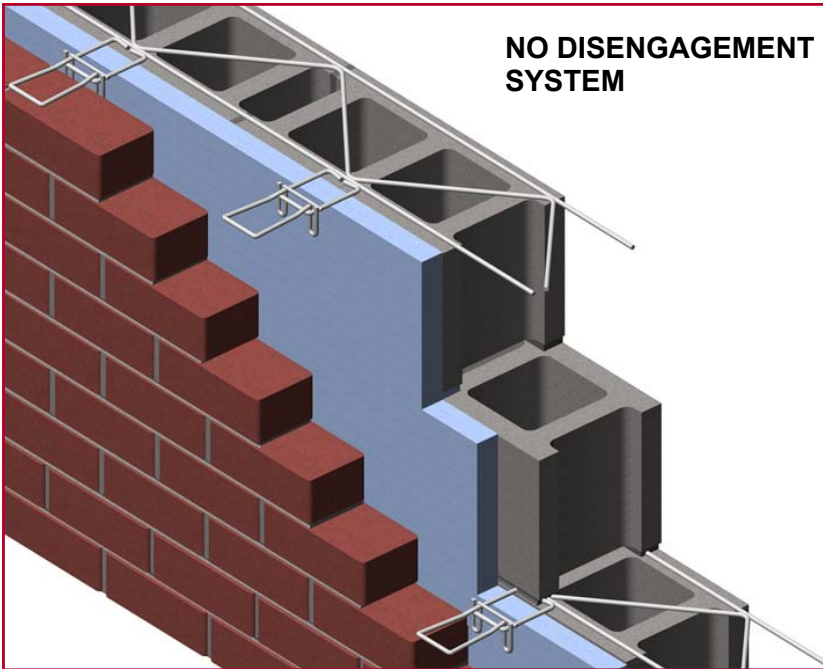

Truss Adjustable Tab Lock



Cross rods welded 16" O.C.

- Tab is butt welded to side rod 16" O.C.
- Height of tab will not exceed 3/16" in bed joint.
- Easier to maintain 3/8" mortar joint.

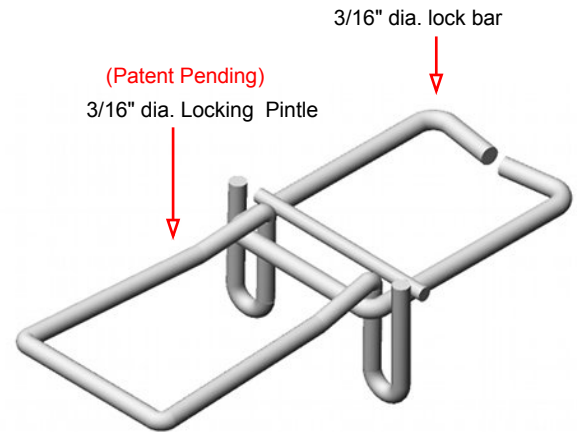

MEETS 150 MPH WINDLOAD AT FULL ENGAGEMENT AND FULL DISENGAGEMENT

- looped hooks meet tolerance of 1/16" between adjustable parts.
- Tab Lock design will not disengage meeting **ACI 530 Code Requirements**.
- Adjustable ties have higher ultimate load values at maximum misalignment of 1-1/4".
- Tab Lock system allows loads to be directly transferred from veneer to stronger back-up wall.
- Locking ties wedge insulation against block back-up.

MATERIAL CONFORMANCE	SIZES / FINISHES												
<p>ASTM A82 / A82M - (Cold drawn steel wire) Tensile Strength - 80,000 psi Yield Point - 70,000 psi</p> <p>ASTM A951 / A951M-06 - (Standard Specification for Steel Wire for Masonry Joint Reinforcement)</p> <p>ACI / ASCE 530 - (Building code requirements for masonry structures Mill Galvanized / Zinc Coating: ASTM A641 / A641M (0.10 Oz per sq ft) Hot Dip Galvanized after fabrication / Zinc Coating</p> <p>ASTM A153 / A153M-B2 (1.50 oz per sq ft) Stainless Steel ASTM 580 / ASTM 580M Type 304 (Type 316 available on special order)</p> <p style="text-align: center;">Recycled Content: Mill Galvanized & Hot Dipped, 82.8% Post-Consumer 17% Post Industrial / Pre-Consumer,</p> <p style="text-align: center;">Stainless Steel, Jl % P!^E0[} • { ^! V O C Content - 0%</p> 	<p><input type="checkbox"/> Hot Dip Galvanized after fabrication / Zinc Coating ASTM A153 / A 153 - B2 (1.50 oz per sq ft)</p> <p><input type="checkbox"/> Stainless Steel ASTM 580 / ASTM 580M Type 304 (Type 316 available on special order)</p> <table style="width: 100%; border: none;"> <tr> <td style="width: 33%;">WIRE SIZE:</td> <td style="width: 33%;"><u>Side Rods</u></td> <td style="width: 33%;"><u>Cross Rods</u></td> </tr> <tr> <td>Standard</td> <td>9 Gauge (.148 in)</td> <td>9 Gauge</td> </tr> <tr> <td>Heavy Duty</td> <td>3/16" (.187 in)</td> <td>9 Gauge</td> </tr> <tr> <td>Extra Heavy Duty</td> <td>3/16" (.187 in)</td> <td>3/16"</td> </tr> </table>	WIRE SIZE:	<u>Side Rods</u>	<u>Cross Rods</u>	Standard	9 Gauge (.148 in)	9 Gauge	Heavy Duty	3/16" (.187 in)	9 Gauge	Extra Heavy Duty	3/16" (.187 in)	3/16"
WIRE SIZE:	<u>Side Rods</u>	<u>Cross Rods</u>											
Standard	9 Gauge (.148 in)	9 Gauge											
Heavy Duty	3/16" (.187 in)	9 Gauge											
Extra Heavy Duty	3/16" (.187 in)	3/16"											

Corporate Office: 400 Rountree Rd Charlotte, NC 28217
TEL: (800) 849-6722 FAX: (704) 525-3761

Mailing Address: P.O. Box 240988 Charlotte, NC 28224



www.wirebond.com

Memphis Plant: 2365 Harbor Ave. Memphis, TN 38113
TEL: (800) 441-8359 FAX: (901) 775-9449

Mailing Address: P.O. Box 13124 Memphis, TN 38113